

# 健身器材

SPORTS  
EQUIPMENT  
FACILITIES

## PLAYGROUND X-ERCISE

2009 DAVID LEADING SPORTS ALL RIGHTS RESERVED

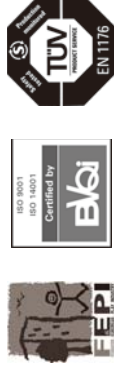

**大衛體育運動器材** 本著增進身心健康、提高生活品質，廣增運動人口以擴大市民參與、落實全民運動的發展，我們致力於提供更好用也更適合國人的戶外健身器材。

**X-ERCISE 戶外健身系列**符合多項國際健身器材標準，安全與品質皆獲國際認證肯定。此外，我們更進一步思考與環境融合美化的關係，提供愛好戶外運動的國人有更愉快的運動健身體驗。

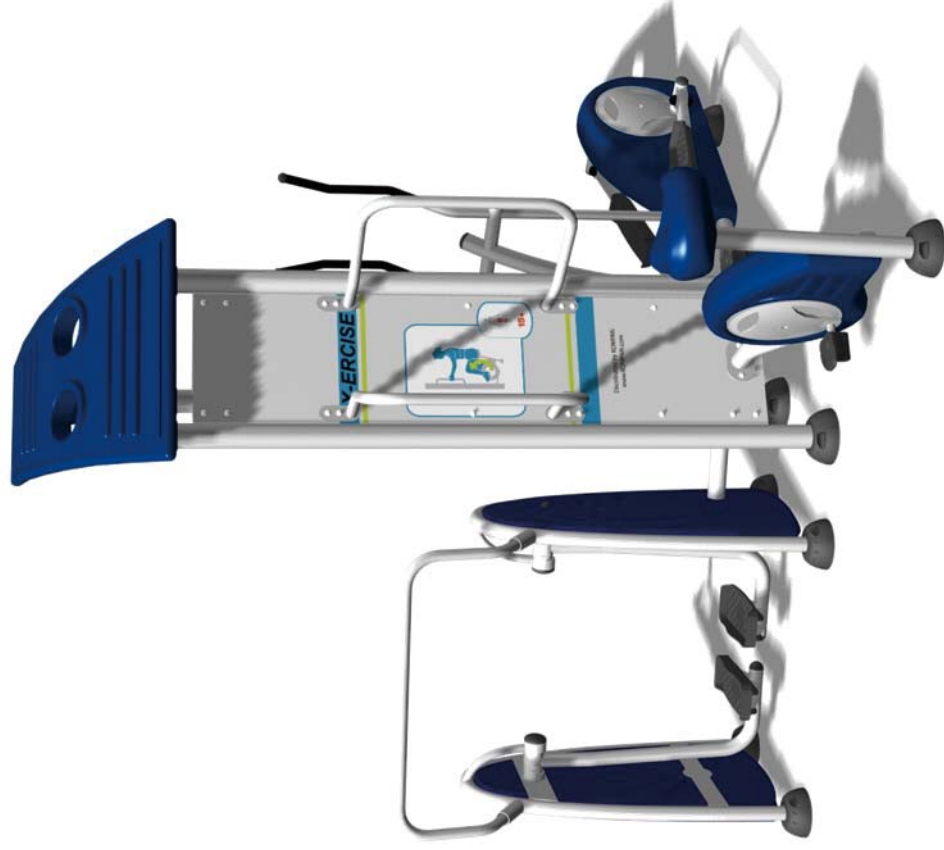

**X-ERCISE**  
MAGNETIC PLAY SPACES

WITH THIS PRODUCT LINES, WE OFFERS  
THE WIDEST SELECTION OF PRODUCTS  
AVAILABLE FOR EVERY AGE GROUP .



DAVID LEADING SPORTS

TEL: +886-2-2715-0034 . 2717-1342 Taiwan

WEBSITE: <http://www.david-sports.net>



# 健身器材



## PLAYGROUND X-ERCISE

2009 DAVID LEADING SPORTS ALL RIGHTS RESERVED



### 腹部訓練器 (仰臥起坐)

功能:

增強腹部肌肉力量，並提升腰部靈活性及柔韌性！



### 交叉循環訓練機

功能:

交叉循環訓練增加身體協調性及靈活度，活動上肢及下肢任何關節，達到有氧運動之效果，並改善且提升身體心肺能力！



### 肩 (關節) 部活動旋轉器

功能:

活動上臂及肩部關節，增加上臂力量，改善肩關節靈活性，並有效舒緩及放鬆肩部的效果！

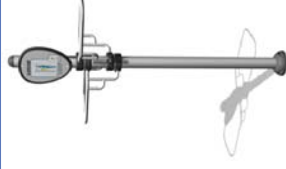

### 雙人上拉器 (引體向上)

功能:

增強上身力量，並改善身體肌肉組成！



### 單人固定式腳踏車

功能:

活動腿部與髖部關節，改善腿部關節靈活性，循環訓練達到有氧運動之效果，有效提升心肺能力！



Installation  
Tekst



DAVID LEADING SPORTS

TEL: +886-2-2715-0034 . 2717-1342 Taiwan

WEBSITE: <http://www.david-sports.net>



# 健身器材



## PLAYGROUND X-ERCISE

2009 DAVID LEADING SPORTS ALL RIGHTS RESERVED



**單人(太空)漫步機**

功能：  
阻力訓練增加下肢關節活動力，提高身體平衡力及協調性，並達到有氧運動，增加心肺能力！

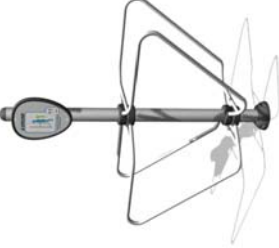

**雙桿撐體器**

功能：  
增強上臂及肩部肌肉力量，提升身體之平衡與支撐力，並有助於紓緩及放鬆腰部肌肉！



**雙人轉(扭)腰器**

功能：  
活動腰部關節，放鬆腰部及背部肌肉，提升腰部靈活度及柔韌性！

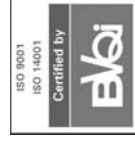

DAVID LEADING SPORTS

TEL: +886-2-2715-0034 . 2717-1342 Taiwan

WEBSITE: <http://www.david-sports.net>

欲知更多產品資訊，歡迎洽詢